

Custom Kitchen Cabinet & Refacing Company

www.RefaceDepot.com

February 8, 2011



125 P2 RAD
Harvest Maple
w/Mocha Glaze



801 C4 191
RTF Antique White



400 E3 118
Ginger Maple

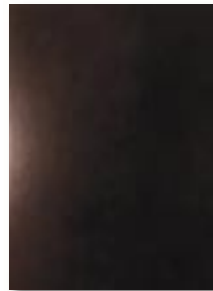

700 Veneer Slab
Espresso Cherry



201 S DL4 SUN
Toffee Maple
w/Bronze



200 S D39 SUN
Espresso Maple

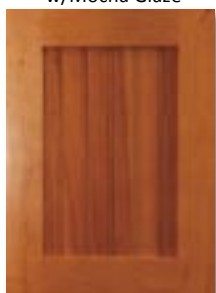

200 E BD 118
Autumn Hickory



142 P2 RAD
Cider Maple
w/Bronze Glaze



375 B SUN
Antique White
w/Mocha Glaze



166 P4 RAD
Cider Cherry
w/Bronze Glaze



144 P4 118
Cordovan Cherry
w/Chocolate Glaze

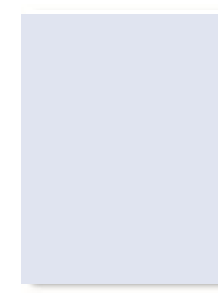

884 White
Laminate



350 RB
Autumn Oak



205 W P2 PRE
Ginger Cherry
w/Chocolate Glaze



125 DL4 RAD
Natural Maple
w/Mocha



410 E 118
Natural Maple



880 Almond
w/Autumn Pulls



401 S SUN
Nutmeg Oak



200 S P1 SUN
Cordovan Maple



201 W P4 PRE
Charcoal Oak



805 C2 113
RTF Matte White



140 P1 RAD
Espresso Maple



800 S5 118
RTF White Woodgrain



800 S2 112
RTF Natural Maple

Product Specifications
Wood Cabinet Doors • Drawer Fronts • Drawer Boxes

Contents

| | Page |
|--|------------|
| Door Specifications, How to Order | 2 |
| Hinging & Boring | 2 |
| Door Styles By Series | 3 |
| Mitered Framed Doors 100 & 300 Series | 4 |
| Mortise & Tenon 200 & 400 Series | 5 |
| Optional Panel & Edge Profiles | 6 |
| RTF & Laminate 800 Series | 7 |
| Slab Edge Banded Veneer 700 Series | 7 |
| Mullion & Frame Only | 8 |
| Moulding & Fillers | 8 |
| Valances & Drawer Boxes & Rollout Trays | 9 |
| Self-Adhesive Veneer & Cut-To-Size Plywood | 9 |
| Wood Species, Finishes, Accent Glazes | 10 |
| Order Form | 11 |
| Wood Descriptions, Warranty | Back Cover |

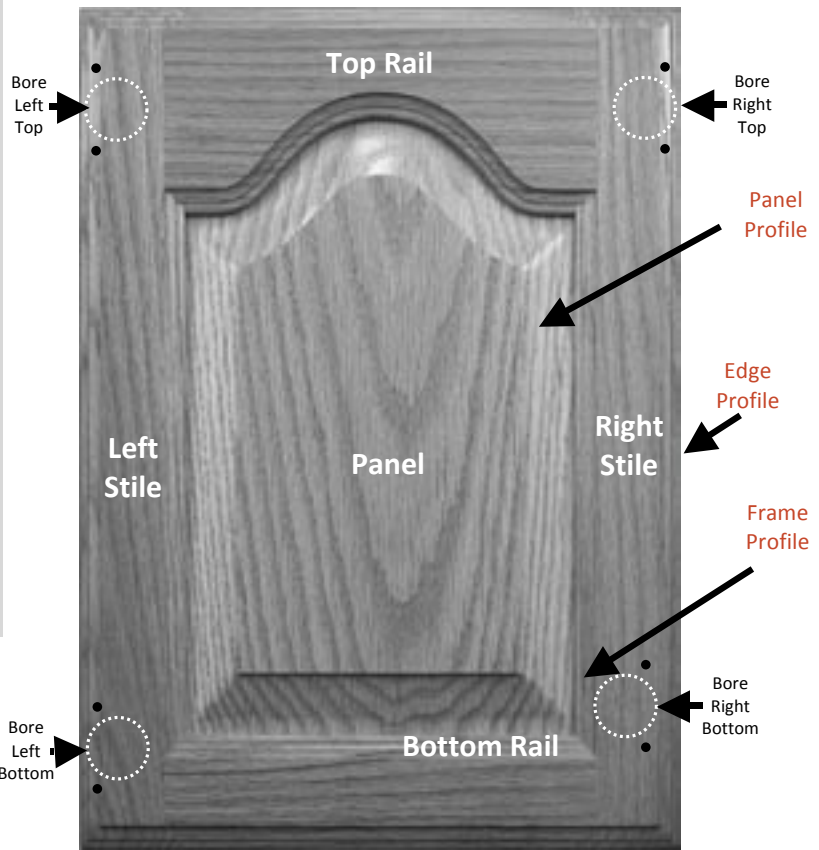

Hinging

Doors over 36" Tall will be Bored for 3 Hinges.

Bore (B1 or B2)... 3 holes drilled on back of door for each hinge, 1 large hole for hinge cup and 2 small holes for Dowel (B1) or Pilot (B2) Holes.

Bore Left (HL)... Looking at front of door, bore holes are on back left side of door.

Bore Right (HR)... Looking at front of door, bore holes are on back right side of door.

Bore Pair (HP)... Boring of two doors covering one opening, one bored left and one bored right.

Hanger Holes... Two small 1/8" diameter holes drilled on back side of door, to hang door while finish is applied.

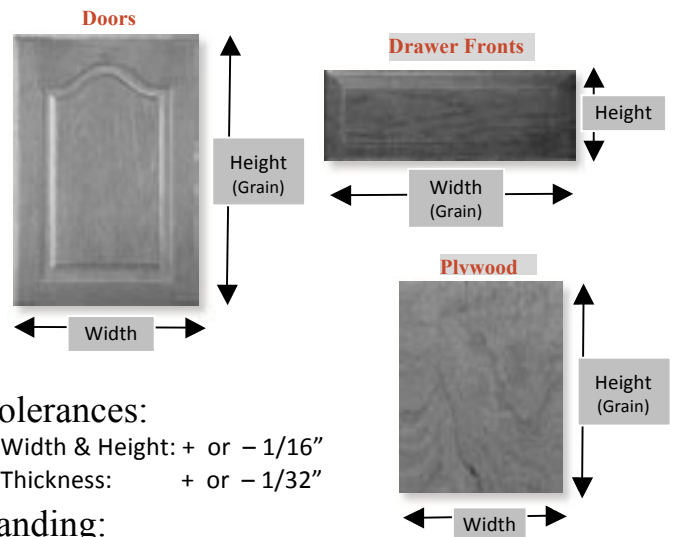

Tolerances:

- Width & Height: + or - 1/16"
- Thickness: + or - 1/32"

Sanding:

- Face of Doors and Drawer Fronts: 220x
- Gross Grain Removed by Orbital Sanding.
- Back of Doors and Drawer Fronts: 180x
- Panel & Edge Profiles: 180x

How to

- **Select:** Wood, Finish Color, and Door Style.
- **Select Optional Profiles:** Frame, Panel, and Edge.
- **Ordering Sizes:** Order by exact overall size.
Width x Height **Do Not Order By Opening sizes.**
- **Check: Minimum Sizes.**

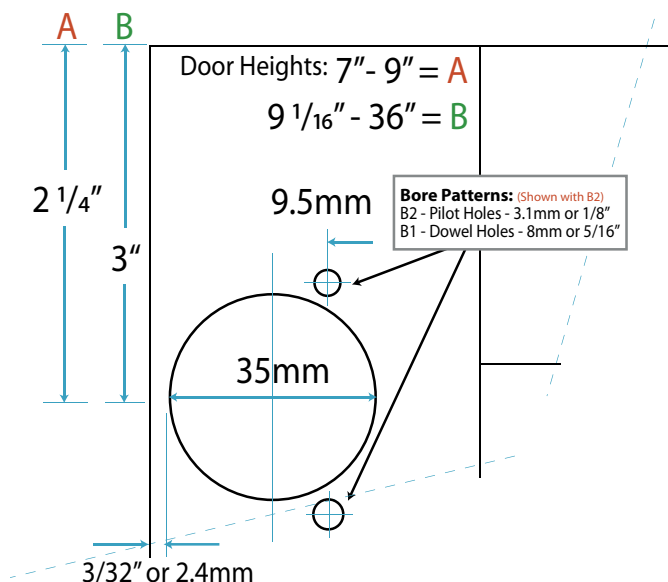

Style By Series:

Mitered Frame - Solid Raised Panel



Mortise & Tenon - Solid Raised Panel



Style Number Breakdown:

200 **W** **P4** **PRE** ← Edge Profile

Door Number Frame Profile Panel Profile

Mitered Framed Doors do not have Frame Profile Letter.

Mitered Frame - Plywood Panel



Mortise & Tenon - Plywood Panel



RTF - Rigid Thermal Foil



Laminate



Slab Veneer

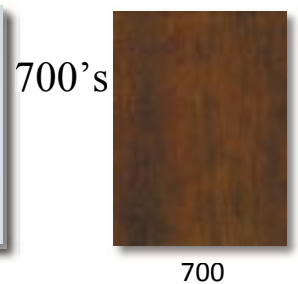

Mitered Frame Doors:

100 Series Solid Panel / 300 Series Plywood Panel Mitered Mortise & Tenon Construction

Optional Panel Profiles See Page #6. Doors Over 48" Tall or 26" Wide will have 2 Panels.

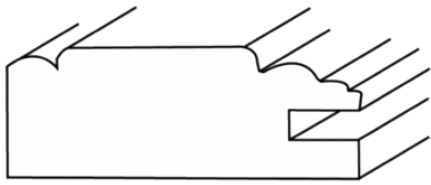

2 1/8" 185 RAD Min. Size 7 x 7
385 RAD Min. Size 5 x 5

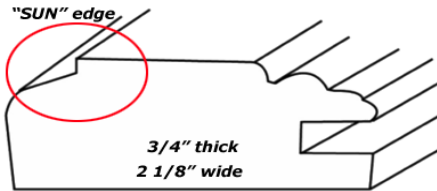

2 1/8" 175 SUN Min. Size 7 x 7
375 SUN Min. Size 5 x 5

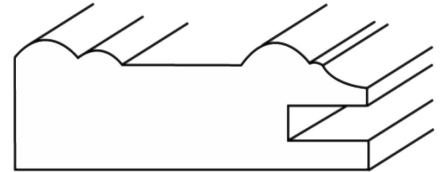

2 1/4" 125 RAD Min. Size 7 1/4 x 7 1/4
325 RAD Min. Size 5 1/4 x 5 1/4

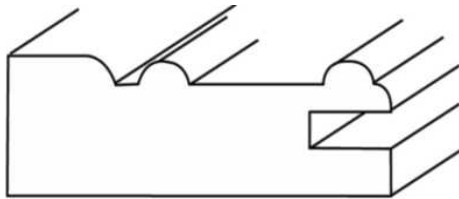

2 3/8" 135 118 Min. Size 7 1/2 x 7 1/2
335 118 Min. Size 5 1/2 x 5 1/2

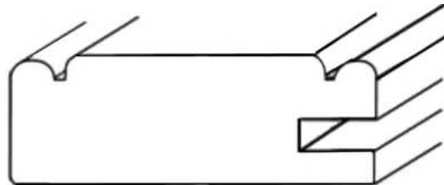

2 1/4" 140 RAD Min. Size 7 1/4 x 7 1/4
340 RAD Min. Size 5 1/4 x 5 1/4

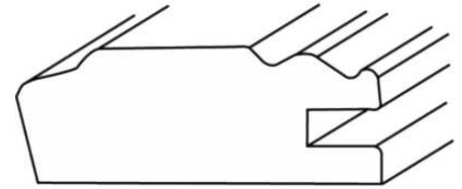

2 1/8" 150 RB Min. Size 7 x 7
350 RB Min. Size 5 x 5

Raised Panel 5 piece Drawer Fronts:

100F Series ... Solid Panel Grain Runs Horizontally.
300F Series ... Plywood Panel Grain Runs Vertically.
"FC" indicates Matching Cut Down Frame.

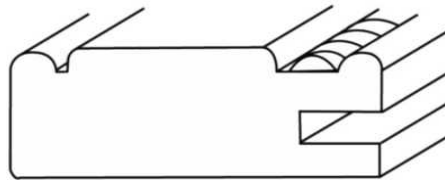

2 1/4" 142 RAD Min. Size 7 1/4 x 7 1/4
342 RAD Min. Size 5 1/4 x 5 1/4

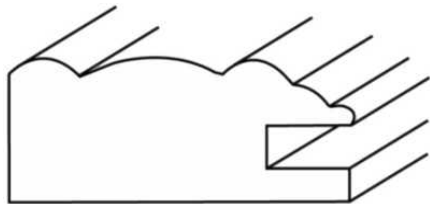

1 3/4" 166FC RAD Min. Size 6 1/2 x 6 1/2
366FC RAD Min. Size 4 1/2 x 4 1/2

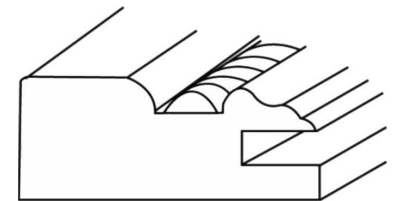

2 1/4" 144FC 118 Min. Size 7 1/4 x 7 1/4
344FC 118 Min. Size 5 1/4 x 5 1/4

Glass Deductions:

| Frames | = Deduction |
|--------|-------------|
| 1 3/4" | = 2 5/8" |
| 2 1/8" | = 3 3/8" |
| 2 1/4" | = 3 5/8" |
| 2 3/8" | = 3 7/8" |
| 2 3/4" | = 4 5/8" |
| 3" | = 5 1/8" |

Deduct from Width & Height. Allows 1/16" Margin Around Glass.

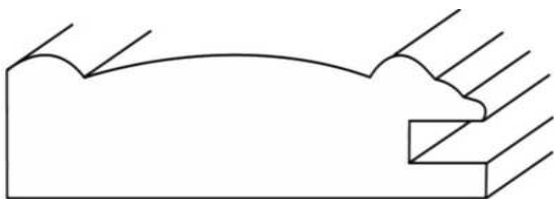

3" 166 RAD Min. Size 8 3/4 x 8 3/4
366 RAD Min. Size 6 3/4 x 6 3/4

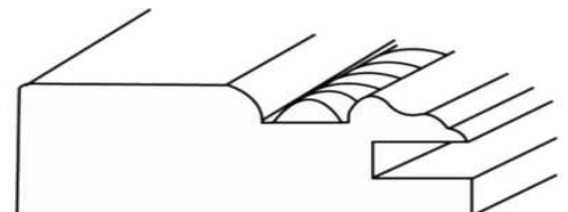

2 3/4" 144 118 Min. Size 8 1/4 x 8 1/4
344 118 Min. Size 6 1/4 x 6 1/4

Mortise & Tenon Frame Doors:

200 Series Solid Panel / 400 Series Plywood Panel

Mortise & Tenon Construction

Optional Panel Profiles & Optional Edge Profiles See Page #6

Optional Frame

Doors Over 48" Tall or 26" Wide will have 2 Panels.

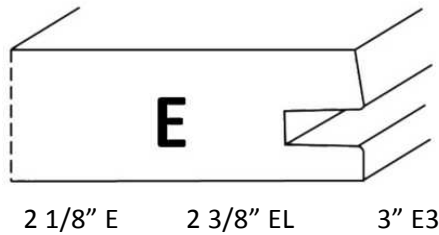
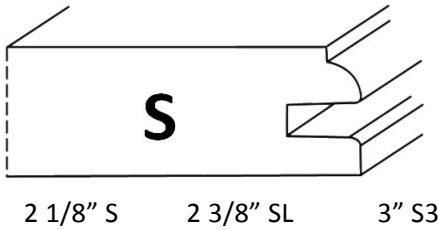

Minimum Sizes are for 2 1/8" Frames:

3" Frames - Add 1 3/4"
2 3/8" Frames - Add 1/2"

Glass Deductions:

| Frames | = | Deductions |
|--------|---|------------------|
| | | Width Height |
| 2 1/8" | = | 3 7/8" 3 3/8" |
| 2 3/8" | = | 4 3/8" 3 7/8" |
| 3" | = | 5 5/8" 5 1/8" |

Deduct from Width & Height.
Allows 1/16" Margin Around Glass.

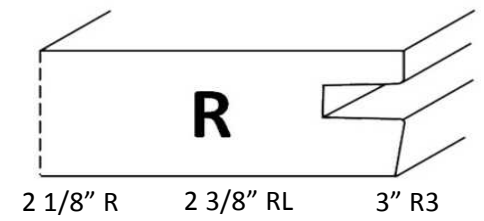
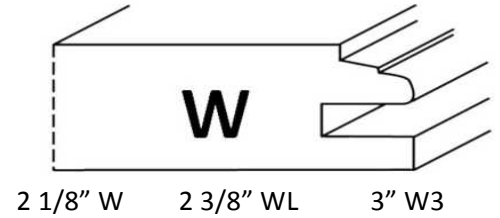
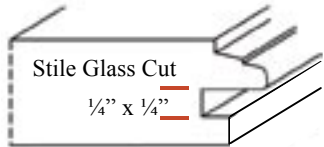
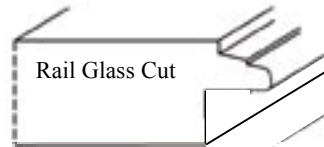

Raised Panel 5 piece Drawer

Fronts:

200F ... Solid Panel Grain Runs Horizontally.
400F ... Plywood Panel Grain Runs



#200

Min Size 7 x 7

#400

Min Size 6 1/2 x 6



#201

Min Size 9 1/2 x 9 1/2

#401

Min Size 7 1/2 x 7 1/2



#205

Min Size 9 1/2 x 7

#405

Min Size 6 1/2 x 6 1/2



#214

Min Size 11 x 10 1/2

#414

Min Size 8 x 7 1/2



#207

Min Size 11 x 9 1/2

#407

Min Size 7 1/2 x 7 1/2



#203

Min Size 9 1/2 x 11 1/2

#403

Min Size 7 1/2 x 8 1/2



#212

Min Size 7 x 14

#412

Min Size 6 1/2 x 9 1/2



#209

Min Size 11 1/2 x 14

#409

Min Size 9 1/2 x 9 1/2



#211

Min Size 11 x 12

#411

Min Size 9 1/2 x 9 1/2



#204

Min Size 9 1/2 x 11 1/2

#404

Min Size 7 1/2 x 8 1/2



#213

Min Size 9 1/2 x 15

#413

Min Size 7 1/2 x 10 1/2



#210

Min Size 11 1/2 x 7

#410

Min Size 9 1/2 x 6 1/2

Optional Panel

Panels P1, P2, P3, & P4 May be Modified to Reduce Minimum Door or 5 Piece Drawer Front Sizes by 1" in Both Height and Width. Order: MP1, MP2, MP3, or MP4. Distance from top of panel Raise to Frame Profile will be 1/2" shorter.

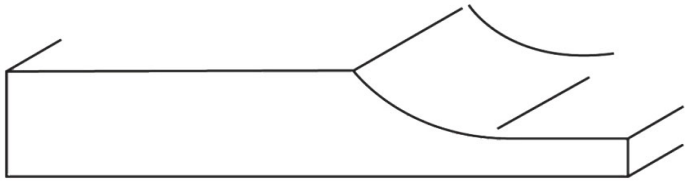

P 1

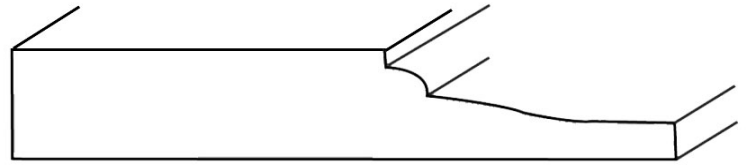

● P2

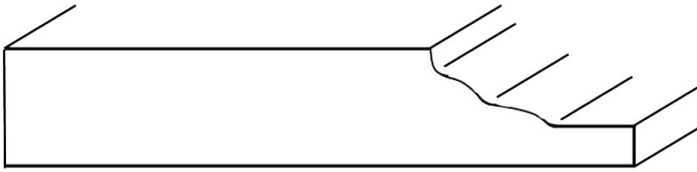

P 3

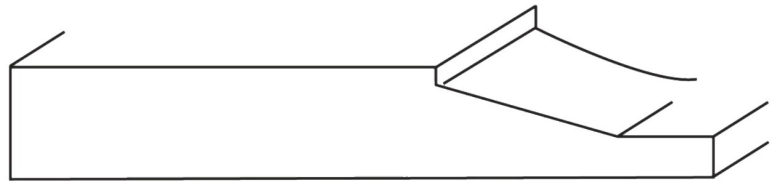

● P4

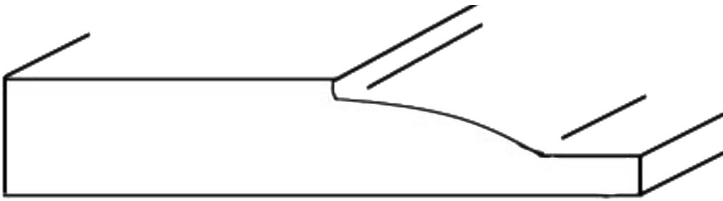

● P6

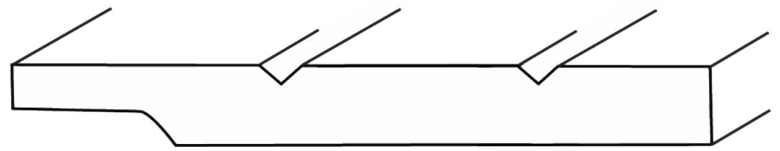

● VG 1 1/2" On Centers

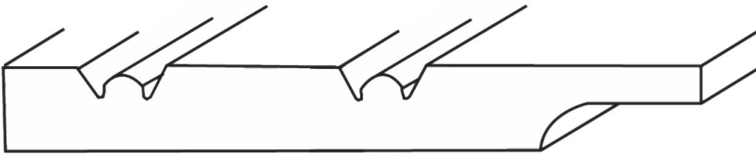

● BD 1 1/2" On Centers

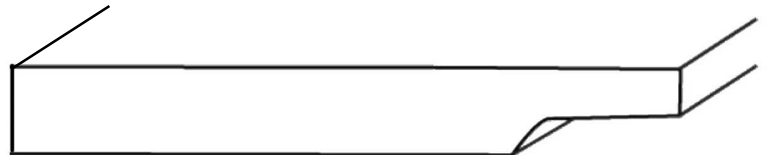

P0

● Available Glazed.

Optional Edge

● Routed Finger Pull Available.

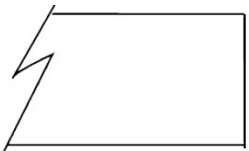

● SQ

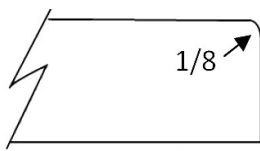

● 118

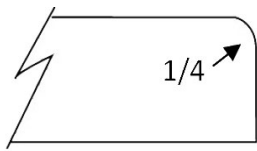

● RAD

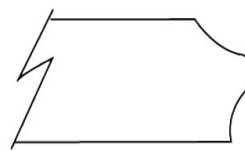

BB

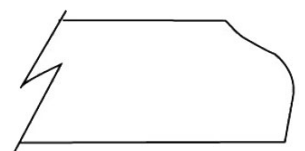

ALP

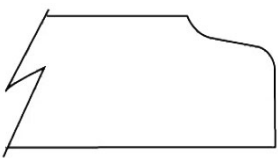

● ER

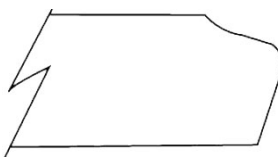

RB

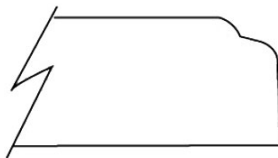

● ● MAC

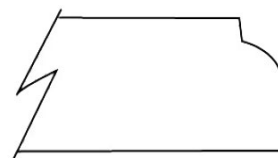

● ● GLH

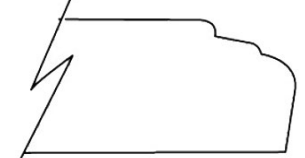

● PRE

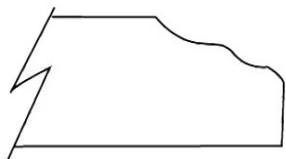

● SA

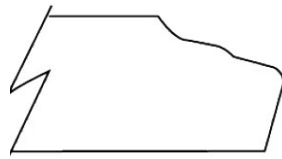

SAB

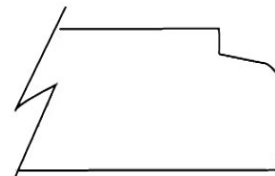

● SUN



● 500FF PRE
Slab Drawer Fronts Only

RTF & Laminate Doors: 800 Series Rigid Thermal Foil & Laminate

RTF: #800 Square ● #801 Cathedral ● #805 Roman Arch

All RTF Drawer Fronts: Grain Runs Horizontally.

Minimum Size: 7 1/2" x 7 1/2" 9" x 10" 9" x 10" FC Drawer Front: 7 1/2" x 5 1/2" #8DF: 6" x 4"
Drawer Fronts: 8DF Slab ● #800F 5 Piece Look Drawer Fronts ● #800FC Cut Down Rails 1 1/4"

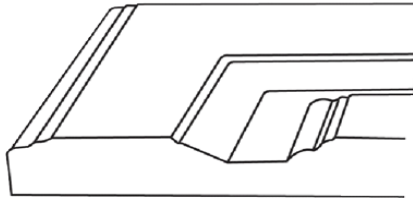

#800 or #801 or #805 C4 191

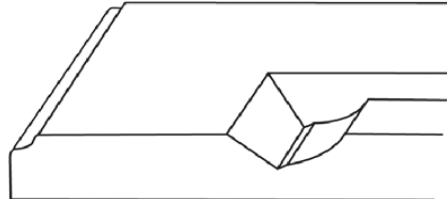

#800 or #801 or #805 C3 113

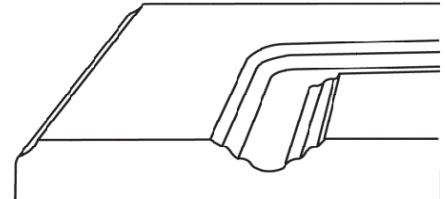

#800 or #801 or #805 C2 113

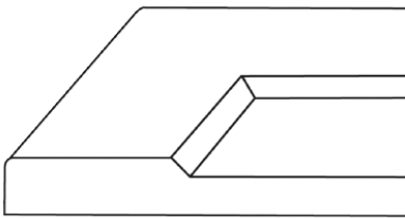

#800 S4 118

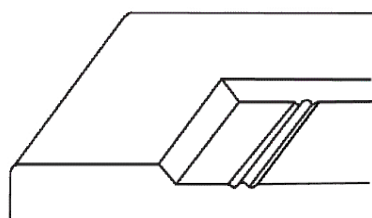

#800 S5 118

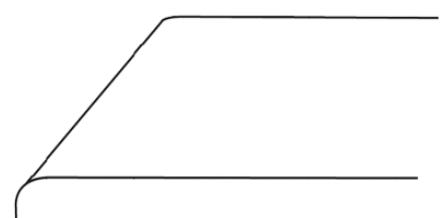

#800 S2 112

Optional Edges: 112 ● 113 ● 118 ● 191

Colors: Matte White, Antique White, Almond, Pickled Maple, Natural Maple, White Woodgrain, Pear, Autumn Oak

Laminate: #880 "C" Wood Pulls Top & Bottom ● #882 "J" Wood Pulls Top & Bottom ● #884 Edge Banded 4 Sides

Minimum Size: Doors: 4 1/2" x 12" Drawer Fronts: 4 1/2" x 3 1/2"

Drawer Fronts: #80F "C" Pulls ● #82F "J" Pulls ● #84F Edge Banded 4 Sides

Laminate Colors: White or Almond

Wood Oak Pulls: Champagne, Autumn, Wheat

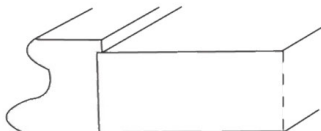

#880 & #80F
3/4" "C" Pulls

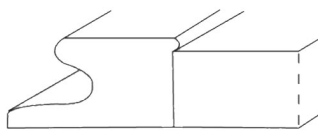

#882 & #82F
1 3/8" "J" Pulls

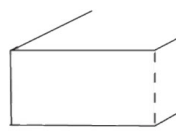

#884 & #84F

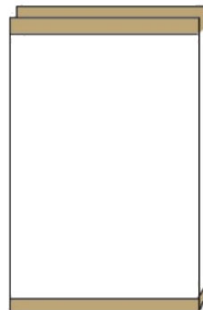

#700 Slab Edge Banded Veneer



#700 & #700F

3/4" Thick Slab
with Veneer Face
& Back and
veneer edge
banding. MDF
Core.

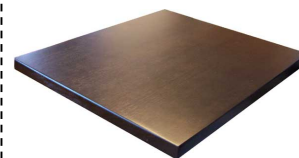

Oak, Maple &
Cherry

All Standard
Finishes except
Glazing

Mullion & Frame Only Doors: ... Available in: 4, 6, 8 or 10

• Mullion doors are available in both Wood and RTF Styles in: 4, 6, 8 or 10 Lites (openings). Examples: DL8 = 8 Lites 2 Wide, 4 High.
 Recommended Number of Lites (openings) for Door Height.

• Up to 25" height: 4 Lites • 26" to 42" height: 6 Lites • 43" to 50" height: 8 Lites • 51" and up height 10 Lites

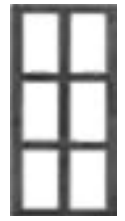
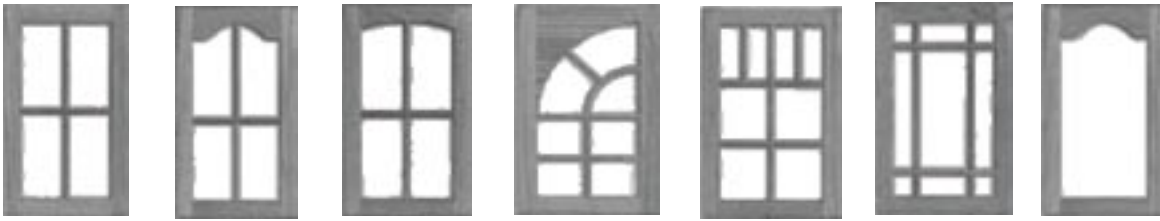

Mullion Inserts: Use with Mitered & Shaker Framed Styles.

200_DL4 ____ Min. Size: 7 x 7
 201_DL4 ____ Min. Size: 9 1/2 x 9 1/2
 205_DL4 ____ Min. Size: 9 1/2 x 7
 292L_DL7 ____ Min. Size: 10 x 20
 200_D48 ____ Min. Size: 15 x 15
 200_D39 ____ Min. Size: 15 x 15
 201_GL ____ Min. Size: 9 1/2 x 9 1/2

Figure Glass or Opening cutout: **Frame width times 2 minus 7/8" for Height. Minus 3/8" for Width.**

Example: $2 \frac{1}{8}'' \times 2 = 4 \frac{1}{4}'' - \frac{3}{8}'' = 3 \frac{7}{8}''$ deducted from Door **Width**.
 $2 \frac{1}{8}'' \times 2 = 4 \frac{1}{4}'' - \frac{7}{8}'' = 3 \frac{3}{8}''$ deducted from Door **Height**.

• Mullion & Frame Only Designs do not include glass. Install using glass clips or clear silicone

Moldings:

• Available Glazed.

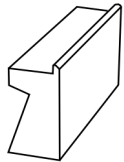

M-2
Light Rail
1 1/2"

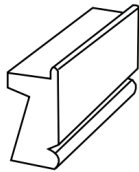

• M-12
Beaded Light Rail
1 1/2"



*M-1
Inside Corner
3/4" x 3/4"



*M-7
Outside Corner
3/4" x 3/4"

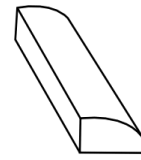

*M-9
Shoe
5/8" x 5/16"

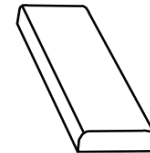

*M-13
Batten
3/4" x 1/4"

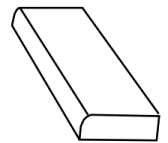

*M-8
Scribe
3/4" x 1/4"



M-4
Shaker Crown
2 5/8"

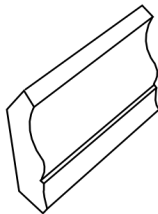

• M-5
Small Crown
1 1/4"

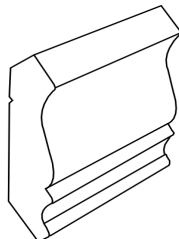

*M-3
Medium Crown
2 1/4"

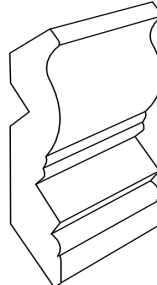

*M-6
Classic Crown
3 1/2"

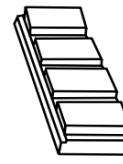

• M-10
Dental
3/4" x 1/2"

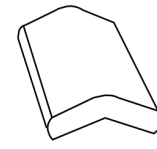

M-14
Angle Corner
1 3/4"

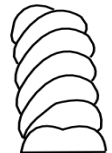

• M-11
Rope
3/4" x 5/16"

* Also available in RTF colors. Profiles may vary slightly from Standard Wood Profiles.

Fillers

• Available Glazed.

• Rosette Caps
Fluted FRC / Beaded
BRC
3" x 3"

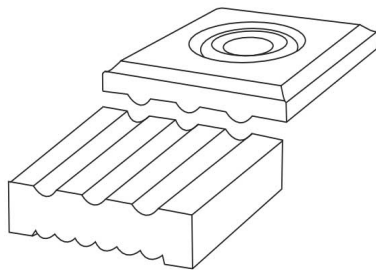

• FBF Reversible Fluted / Beaded
Filler

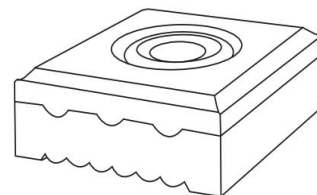
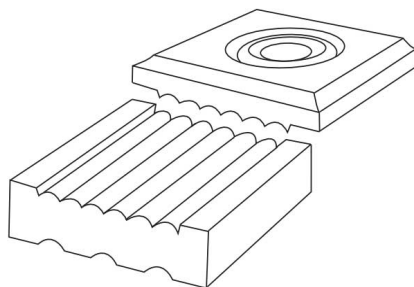

• Fluted

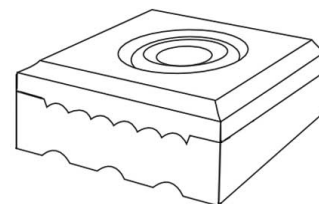

• Beaded



Valances

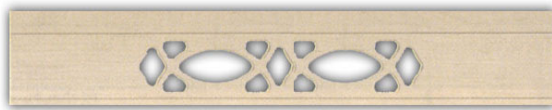

Val-EC 5" High



500 Val-SQ

● Available Glazed.



● Val-SV with GLH Edge 6" High



● Val-AV with GLH Edge 6" High

Drawer Boxes & Rollout

Note: Specify Rollout Tray or Drawer Box on order form.

Custom Widths: Up to 36" Wide

Standard Heights: 3 1/8", 5 1/8" or 7 7/8"

Standard Depths: 15", 18" or 21"

- Measure opening width and deduct 1"
- Rollout tray, deduct 1 1/2"
- Rollout trays come with a front stop.

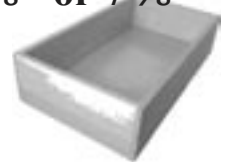

For Widths: • Order Any Width to 36"

Heights: • 3 3/4" - 5 1/2" Order 3 1/8" Height • 5 1/2" - 8 3/4" Order 5 1/8" Height • 8 3/4" - 17" Order 7 7/8" Height

Cabinet Depths: • 17 1/2" - 18 1/2" Order 15" Depth • 20 1/2" - 21 1/2" Order 18" Depth • 23 1/2" - 24 1/2" Order 21" Depth

Depths between 18 1/2" to 20 1/2" or 21 1/2" to 23 1/2", or over 24 1/2" require additional filler strips, not included.

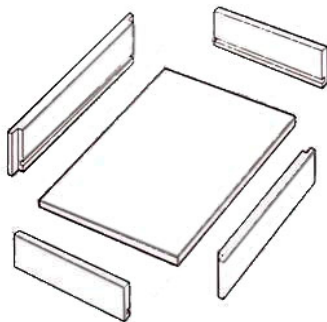

5/8" Hardwood Sides
1/4" Plywood Bottom

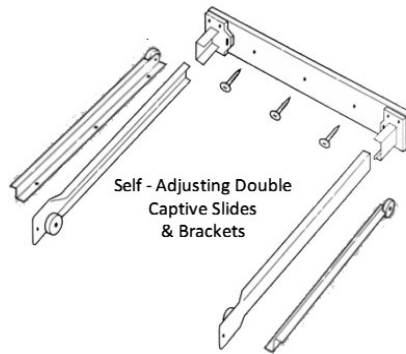

Self - Adjusting Double Captive Slides & Brackets

Rollout Trays: When measuring allow for hinge clearance.

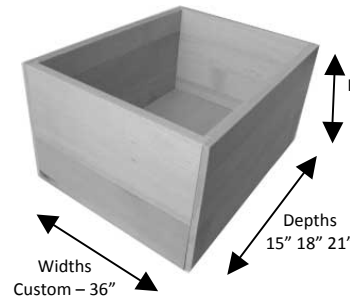

Rollout Trays Have Front Stops.

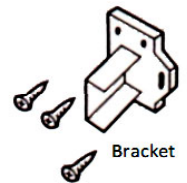

Bracket

Wood Self-Adhesive-Backed Veneer 1/85" thick

24" x 96" Oak, Maple, Cherry, Hickory & RTF - All finishes except Glazing

Due to Limitations in Manufacturing, Adhesive may not extend to all edges. Trimming may be required.



Veneer Applicator Tool for SAC



Cut - To - Size 1/4" (5.2mm)

All Sizes Up To 48" x 96" Oak, Maple, Cherry, Hickory, & RTF

All finishes except Glazing

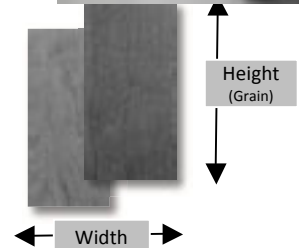

Wood Species:

- Oak** This extremely popular hardwood features a unique blend of strength and enduring beauty. Wood patterns will vary, as will the colors, ranging from warm, soft browns to near white. The variety of grains and the proper stain results in an eye-pleasing color gradation throughout the cabinet.
Autumn – Charcoal – Nutmeg – Champagne –Wheat
- Cherry** For a look of elegance and luxury, cherry cabinets are unmatched. This solid hardwood possesses rich hues that vary from light red to deep reddish brown. Known for its fine, tight grain patterns, cherry will take stain exceptionally well and will darken over time with exposure to light.
Cider – Cordovan – Ginger – Espresso
- Hickory** An open-grained wood that offers a wide range of color possibilities, hickory provides a truly distinctive look. Grain patterns can be bold and irregular, while color can range from white to chocolate. Hickory's strength and shock resistance allow it to withstand rigorous daily use.
Autumn – Cider – Natural
- Maple** The clean simplicity of maple doors makes them the ideal choice for either contemporary or traditional decor. An exceptionally strong and heavy wood, maple is characterized by its white or creamy color. It features even, closely spaced grain with burls, pin knots, mineral streaks and tiger stripes to add to its unique personality. Maple doors provide a smooth, radiant look when finished with a light stain.
Cider – Ginger – Harvest – Toffee – Natural –Espresso – Champagne – Antique White –Cordovan

Finishes:

OAK

Color: Autumn Champagne Wheat Charcoal Nutmeg Almond White

LAMINATE

Almond White

Wood

- Autumn
- Wheat
- Champagne

MAPLE

Color: Cider Champagn Ginger Natural Toffee Cordovan Espresso Harvest Antique White

HICKORY

Color: Autumn Cider Natural

Touch-Up:

- Stain Pens
- Putty Sticks

CHERRY

Color: Cordovan Cider Ginger Espresso

RTF

Color: Autumn Oak Pickled Maple White Woodgrain Natural Maple Almond Antique White Matte White Pear

Accent Glazes:

ALMOND – BRONZE – CHOCOLATE – MOCHA
 Available on all Finished Wood Species, *except Oak*



| | | Finish Options | | | | | | | | | | | | | |
|---------|--|----------------|--------|-----------|----------|-------|----------|----------|--------|---------|---------|--------|--------|-------|--------|
| | | Antique White | Autumn | Champagne | Charcoal | Cider | Cordovan | Espresso | Ginger | Harvest | Natural | Nutmeg | Toffee | Wheat | Glazes |
| Oak | | | • | • | • | | | | | | • | | | • | |
| Maple | | • | | • | | • | • | • | • | • | • | | • | | • |
| Hickory | | | • | | | • | | | | | • | | | | • |
| Cherry | | | | | | • | • | • | • | | | | | | • |

Custom Kitchen Cabinet & Refacing
 98 Monarch Drive
 Amherst, NY 14226
 Fax (716) 832-9294 Phone (716) 832-9737

ORDER FORM

ORDER EXACT OVERALL DOOR SIZES

FIRM ORDER

QUOTE ONLY

DATE

| |
|----------------|
| NAME |
| ADDRESS |
| CITY/STATE/ZIP |
| PHONE NUMBER |
| EMAIL ADDRESS |

| |
|----------------|
| SHIP TO |
| ADDRESS |
| ADDRESS (CONT) |
| CITY/STATE/ZIP |

UNFINISHED

PREFINISHED

COLOR: _____

| DOORS | | | | | DOORS (continued) | | | | | DRAWER FRONTS | | | | |
|----------------|----------|-------|--------|---------|-------------------|----------|-------|--------|---------|---|----------|-------|--------|---------|
| WOOD TYPE : | | | | | WOOD TYPE : | | | | | WOOD TYPE : | | | | |
| DESIGN # _____ | | | | | DESIGN # _____ | | | | | DESIGN # _____ | | | | |
| | | | | | | | | | | | | | | |
| | QUANTITY | WIDTH | HEIGHT | OPTIONS | | QUANTITY | WIDTH | HEIGHT | OPTIONS | | QUANTITY | WIDTH | HEIGHT | OPTIONS |
| 1 | | | | | 22 | | | | | 1 | | | | |
| 2 | | | | | 23 | | | | | 2 | | | | |
| 3 | | | | | 24 | | | | | 3 | | | | |
| 4 | | | | | 25 | | | | | 4 | | | | |
| 5 | | | | | 26 | | | | | 5 | | | | |
| 6 | | | | | 27 | | | | | 6 | | | | |
| 7 | | | | | 28 | | | | | 7 | | | | |
| 8 | | | | | 29 | | | | | 8 | | | | |
| 9 | | | | | 30 | | | | | 9 | | | | |
| 10 | | | | | 31 | | | | | 10 | | | | |
| 11 | | | | | 32 | | | | | 11 | | | | |
| 12 | | | | | 33 | | | | | 12 | | | | |
| 13 | | | | | 34 | | | | | 13 | | | | |
| 14 | | | | | 35 | | | | | 14 | | | | |
| 15 | | | | | 36 | | | | | 15 | | | | |
| 16 | | | | | 37 | | | | | OPTIONAL ITEMS (WRITE ADDITIONAL PIECES ON SEPARATE SHEET) | | | | |
| 17 | | | | | 38 | | | | | 1 | | | | |
| 18 | | | | | 39 | | | | | 2 | | | | |
| 19 | | | | | 40 | | | | | 3 | | | | |
| 20 | | | | | 41 | | | | | 4 | | | | |
| 21 | | | | | 42 | | | | | 5 | | | | |

Wood Description

Custom Kitchen Cabinet & Refacing, Inc. uses finishes that protect and enhance the natural beauty of wood. Extra care is taken to assure a uniform finish. Because we are dedicated to customer satisfaction we feel that it is important to explain some of the characteristics of our finishes on hardwood. Like fingerprints, characteristics differences in color and grain are produced by nature in every tree. These variations are what create the beauty and interest found in wood. The variations in color, grain and texture will cause variations in the finish, even though identical finishing processes are applied. These variations are considered a natural characteristic of hardwood and are not a defect. We hope that you will appreciate and enjoy this beauty.

Limited Warranty

Custom Kitchen Cabinet & Refacing, Inc. warrants all standard products for one year from date of shipment against warpage to these tolerances. Doors: Raised panel doors less than 22" in width and 48" in height are warranted against warpage of more than 1/8". Frames and plywood insert panel doors less than 22" in width and 48" in height are warranted against warpage of more than 1/4". Doors more than 22" in width and/or 48" in height are not warranted. Drawer fronts: Drawer fronts less than 8" in height and 30" in width are warranted against warpage of more than 1/4". Drawer fronts more than 8" in height (across the grain) or 30" in width (with the grain) are not warranted. Warranty: Warranty covers replacement of door and shipping only. Custom Kitchen Cabinet & Refacing, Inc. assumes no responsibility for damage, other than warpage, incurred by the customer during storage, handling or finishing process. All claims for shortages or damage must be made within 10 days of receipt. Due to the natural characteristics of wood, metal, vinyl and stains, all items will not match exactly. Example: Real wood will not match RTF SAC exactly. Items are manufactured to blend in color and textures. Display sample colors may vary slightly from actual product received.

Custom Kitchen Cabinet
& Refacing Company

www.RefaceDepot.com

716.832.9737

1.888.40.REFACE (888.407.3322)